

Please carefully read this manual before using this product.  
Make sure you are familiar with all of the safety and  
usage instructions.

Keep this manual in a safe place for future reference.

## Installation and Operating Manual

# Salamander Grill

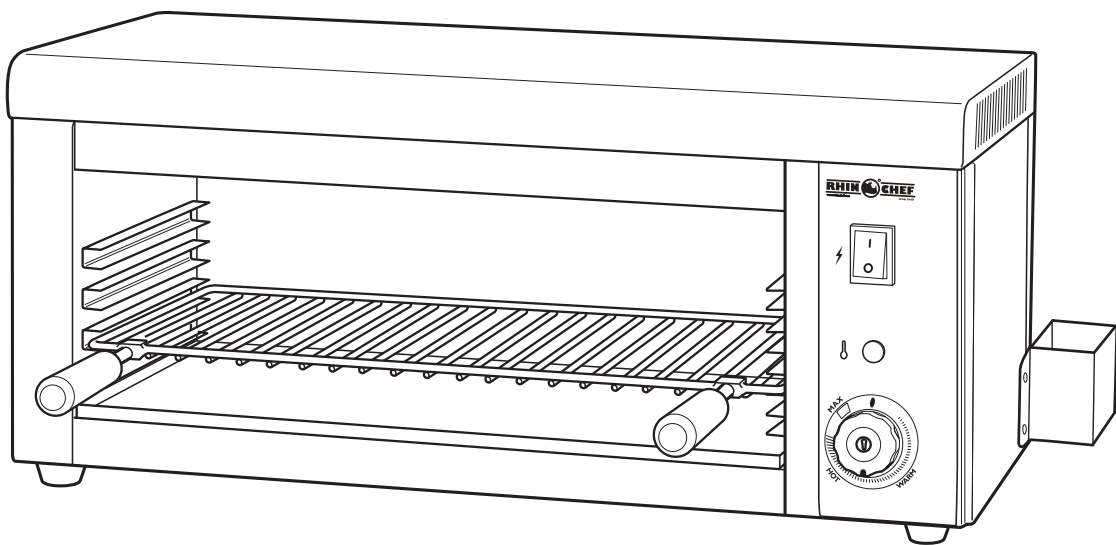

**RSG1**

### Contact Information

Rhinochef, County Oak Way, Crawley, West Sussex, RH11 7ST

**Customer Helpline: +44 (0) 1293 652 500** (9am - 5pm Monday to Friday) • Fax: +44 (0) 1293 652 555

Email: [info@rhinochef.com](mailto:info@rhinochef.com) • [www.rhinochef.com](http://www.rhinochef.com)



# SAFETY INFORMATION



**WARNING:** The installation, maintenance and servicing of this product must be carried out by a qualified technician.

You should consult local and national standards to comply with the following:

- Health & safety at work legislation
- BS EN Codes of practice
- Fire precautions
- IEE Wiring regulations
- Building regulations

**WARNING:** Incorrect installation, unauthorised modifications, refitting, adjustments, dismantling or maintenance could result in damage to the grill, damage to property or serious injury. All repairs, maintenance and adjustments must be carried out by a qualified technician.

**WARNING:** RISK OF SEVERE BURNS. Take caution when using this product.

**WARNING:** ELECTRIC SHOCK RISK. **DO NOT** use when the power cord is damaged.

**WARNING:** For safety reasons, this product **MUST** be earthed.

The terminal marked  is for equipotential bonding.

**WARNING:** This is a commercial product and must only be used by a trained operative who has read and fully understands this manual. It must not be used by children or persons with reduced physical, sensory or mental capabilities.

**IMPORTANT:** This product is intended for grilling food only. It is not intended for any other styles of cooking. Its temperature operation range is 50 - 250°C.

Before using the product, ensure that the electricity supply conforms to the rating markings on the product.

Check power cord for damage prior to every use. If damaged it can only be replaced by the manufacturer or a qualified technician.

**IMPORTANT:** The product should be given a visual safety check over every day to help prevent accidents.

**IMPORTANT:** The product should not be used if operator feels there is anything wrong with it. The problem should be referred to the manufacturer or a qualified technician.

Incorrect use of the grill, other than its intended use, can cause damage to it and be dangerous.

The grill surfaces and control panel may be damaged by hard or sharp objects.

**DO NOT** use a power supply that is not compatible with safety standards.

**DO NOT** store any type of flammable liquid, gas or other similar items near or around this product.

**CAUTION:** Be aware that surfaces of the product may be hot before and after it has been used - RISK OF SEVERE BURNS.

**DO NOT** use the product during a thunderstorm. To avoid it being damaged by a lightning strike, unplug it from electricity supply prior to the storm.

Before cleaning, unplug the product from the mains power supply.

Allow the grill to cool before cleaning.

**DO NOT** use wet cloths, steel wool pads, abrasive creams or acid based cleaners.

**DO NOT** spray or splash water directly onto the product - RISK OF ELECTRIC SHOCK.

**DO NOT** submerge product, electric plug or power lead in water or other liquids. If the product has been soaked, it must be dried and checked by a trained technician before further use.

When not in use, turn the temperature control to the '0' position and unplug the product from the mains power supply.

Store product in a safe, clean, dry, well ventilated place if it is not going to be used for any length of time.

**EXTREME CAUTION:** Failure to follow instructions could result in damage to product, damage to property or serious injury

To avoid risk of suffocation to children or animals, dispose of the plastic bags and packaging correctly.

For use with an earthed wall socket.

For indoor use only. Must **NOT** be used outdoors.

Not suitable for use with an extension cable.

Keep grill and power cord out of reach of children and keep pets clear during use.

**DO NOT** position or use product underneath or near flammable items such as curtains, shelves, cupboards etc - FIRE HAZARD

**DO NOT** cover the product with anything - FIRE HAZARD

**DO NOT** try to dislodge food from the product when it is plugged in - RISK OF ELECTRIC SHOCK.

**DO NOT** allow the power cord to hang over the edge of a table or work surface on which the product stands.

**DO NOT** allow the power cord to come into contact with a heat source.

**DO NOT** use on or near direct heat sources.

**DO NOT** operate product with wet hands.

**DO NOT** operate product if damaged, or the power cord, plug or it is damaged in any way.

**DO NOT** leave product unattended when in use.

**DO NOT** attempt to service the product yourself. Contact a qualified technician.

**DO NOT** use attachments other than those recommended by the manufacturer.

**CAUTION:** Do not pull or drag the product by the power cord.

The product must be placed and operated on a safe, flat and stable surface.

Children should be supervised to ensure that they do not play with the appliance.

# THE SALAMANDER GRILL

Thank you for purchasing this Rhinochef Salamander Grill. The Salamander Grill is the ideal for providing the finishing golden touch to the tops of lasagne, pies or desserts. With three grill positions, the Salamander is a versatile and convenient way to create grilled dishes in a bustling kitchen.

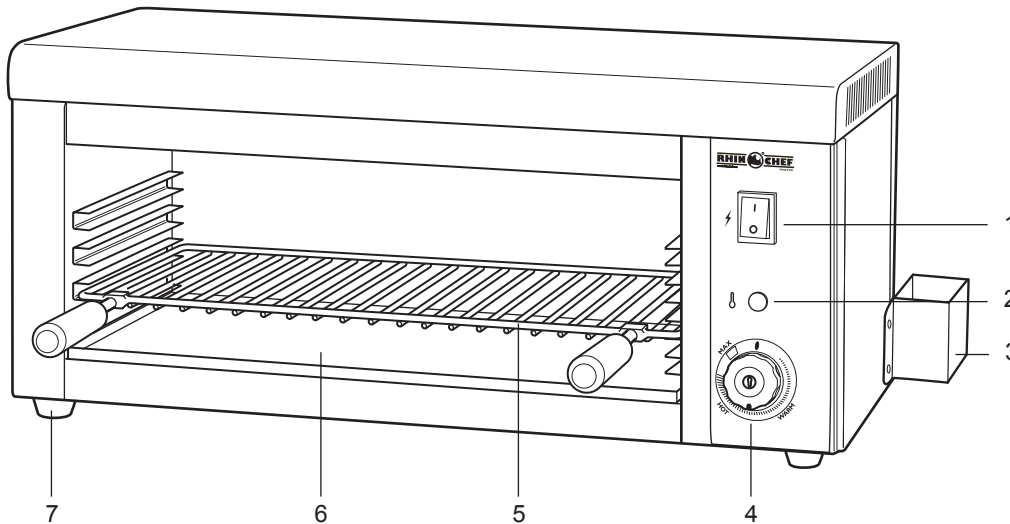

## Salamander Grill Parts:

1. Power on
2. Power light
3. Wall spacer
4. Temperature control
5. Grill rack
6. Drip tray
7. Rubber feet

# INSTALLATION

Remove all protective film from the grill before use.

This grill is a plug-in product but commercial safety regulations require additional earthing to be carried out.

Only a suitably qualified technician should install the product.

There is an earth bolt at the back of the grill .

Complying fully with safety regulations, connect the earth wire with suitable cable.

The grill should be positioned where it can be easily connected to the power supply and where there is enough room to use and maintain the product.

The wall spacers on the back/side will ensure there is an air gap around the machine.

A suitable switch, fuse breaker and plug socket should be installed near the grill.

You may see smoke coming from the elements when the machine is first switched on, this is normal.

# USING THE SALAMANDER GRILL



**WARNING: RISK OF SEVERE BURNS. When used, parts of the grill will be hot to the touch.**

**WARNING: Use heat protective gloves when moving food in or out of the grill.**

1. Before using the product, ensure that the electricity supply conforms to the rating markings on the grill and check there is no damage to the power cord.
2. Adjust the position of the rack/tray in the oven according to the size of dish to be grilled.
3. Plug the grill into the wall socket and make sure the power is switched on.
4. Turn temperature control dial (4) to WARM or HOT settings whereby the elements will cycle on and off to maintain a regular temperature or set to MAX setting whereby the element will stay on constantly at maximum temperature.
5. To turn the grill on, press the power switch (1) grill will start to heat.
6. When cooking is finished, the temperature control (4) must be turned to the '0' position and the timer turned to the off position.
8. Unplug the grill from the mains power socket when not in use.

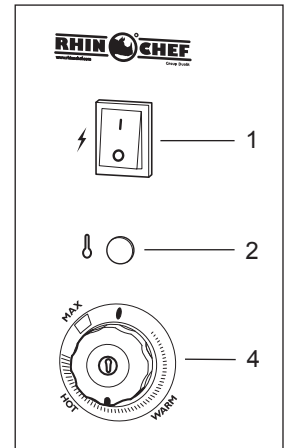

## Care, Maintenance, Storage and Transportation

**IMPORTANT:** The product must be regularly inspected and maintained by a qualified technician.

**IMPORTANT:** Always unplug grill from the mains power socket and allow to cool completely before cleaning.

**DO NOT** use a water jet, spray or splash water directly onto the product.

**DO NOT** submerge product, electric plug or power cord in water or other liquids.

Clean the grill chamber at least once a week, more often if grill is used frequently.

Remove the drip tray and rack and wash them in warm water and dry.

The inside of the oven should be cleaned using a non abrasive cleaning pad and a cleaner suitable for ovens/grills.

Only return the drip tray and rack to the oven when they are fully dry.

When not in use, turn the temperature control to the '0' position and unplug the grill from the mains power supply.

Store product in a safe, clean, dry, well ventilated place if it is not going to be used for any length of time.

Handle the grill with care when transporting.

**DO NOT** turn the grill upside down. This will help prevent the possibility of damaging it.

# TROUBLE SHOOTING

If a problem occurs that does not appear on this table, stop using the grill and seek help from the manufacturer, a qualified technician or an authorised dealer.

Problem	Cause(s)	Solution(s)
Power light stays on when power off.	Fuse may be blown.	Replace fuse.
The mains power is on but the heating elements are not working.	1. The element may have failed.	1. Contact a qualified technician for repair advice.
Temperature control is working but the indicator light is off.	1. Indicator light is not properly connected. 2. Indicator light is broken.	1. Wiring needs to be looked at. Contact a qualified technician for repair advice. 2. Replace indicator light. Contact a qualified technician for repair advice.

## Technical Specifications

Model number	RSG1
<b>Description</b>	Grill
<b>Voltage</b>	230V~
<b>Power</b>	2KW
<b>Oven chamber dimensions</b>	456 x 260 x 190(ht) mm
<b>Overall dimensions</b>	690 x 400 x 280 (ht) mm
<b>Temperature range</b>	50 - 250°C
<b>Weight</b>	13kg
<b>Casing material</b>	Stainless steel
<b>Oven interior material</b>	Stainless steel
<b>Feet</b>	Rubber

# GUARANTEE

This appliance is of excellent quality and construction. However, if any defects in materials or workmanship do appear during the relevant guarantee period, we will, at our discretion, either repair or replace the defective parts, free of charge, subject to the terms and conditions of our Guarantee shown below.

This Guarantee covers both parts and labour. Carriage is not included.

Your Guarantee period is as follows:

- 1 year

This Guarantee provides benefits which are additional to, and do not affect, your statutory rights. This Guarantee does not cover the cost of returning the product to the dealer from whom it was purchased or to ourselves. This Guarantee applies only to products sold and located in mainland Great Britain. It does not cover liability in respect of or replacement of plugs, cables or fuses and also does not cover defects due to:

- Failure to use or maintain product in accordance with Dualit's instructions
- The product being connected to an unsuitable electricity supply
- Accidental damage to or abuse or misuse of the product
- The product has not been modified except by Dualit or approved agent
- Dismantling of or interference with the product
- Accidental breakage or damage
- Operational misuse, wear and tear from normal usage, incorrect adjustment and neglect
- Incorrect installation, maintenance, modification or unauthorised service work
- Theft or attempted theft of the product

Before returning any product under this Guarantee, please check that:

- You have followed the product instructions correctly
- Your mains electricity supply is functional
- The defect is not due to a blown fuse

If you wish to claim under this Guarantee you should:

- Send the product, postage or carriage paid, to the dealer from whom it was purchased or to Dualit direct
- Ensure that the product is clean and packed carefully (preferably in its original carton)
- Enclose details of your name, address and telephone number and when and where the product was purchased, together with proof of purchase (e.g. a till receipt)
- Give exact details of the nature of the defect

This Guarantee does not cover any other claims whatsoever, including, without limitation, any liability for incidental, indirect or consequential damage, nor does it cover any claims for conversion or modification or for the costs of repair carried out by any third party without the prior consent of Dualit. If replacement parts are fitted to the product this will not extend the period of the guarantee.

For further advice contact the Rhinochef Customer Helpline on: +44 (0)1293 652 500 (09:00 to 17:00 Monday to Friday).

Alternatively, email Dualit at [info@rhinochef.com](mailto:info@rhinochef.com) or visit [www.rhinochef.com](http://www.rhinochef.com).

## Disposal and the Environment



This product is covered by the waste electrical and electronic equipment (WEEE) regulations. It should not be discarded with normal household waste, but taken to a local collection centre for recycling. For further information, please contact the local authority or approved disposal agency.

Dispose of all packaging responsibly.



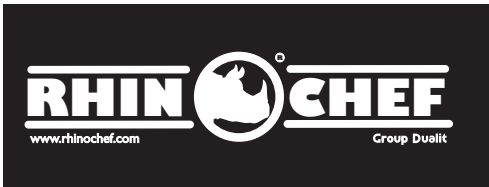

Rhinochef, County Oak Way, Crawley, West Sussex, RH11 7ST  
Telephone: +44 (0) 1293 652 500 Fax: +44 (0) 1293 652 555  
Email: [info@rhinochef.com](mailto:info@rhinochef.com) [www.rhinochef.com](http://www.rhinochef.com)

