

## Installation and Operating Manual

# Contact Grills

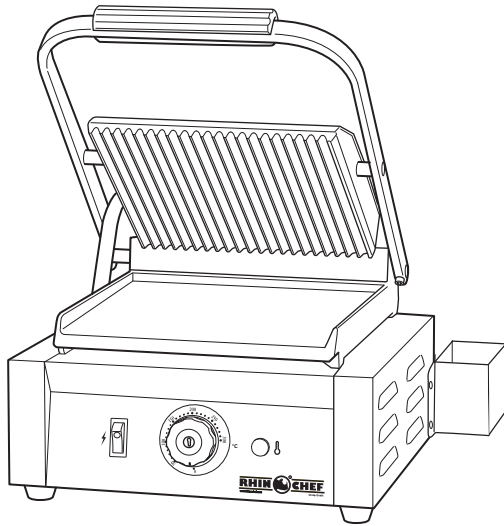

**Single Contact Grill RCG1**

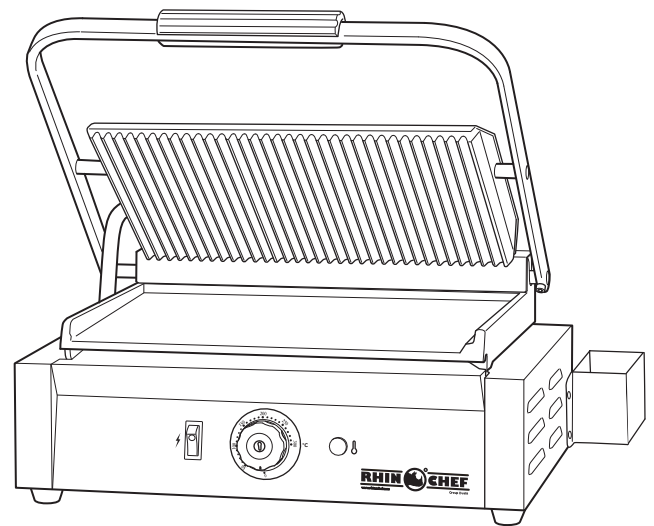

**Panini Grill RPG2**

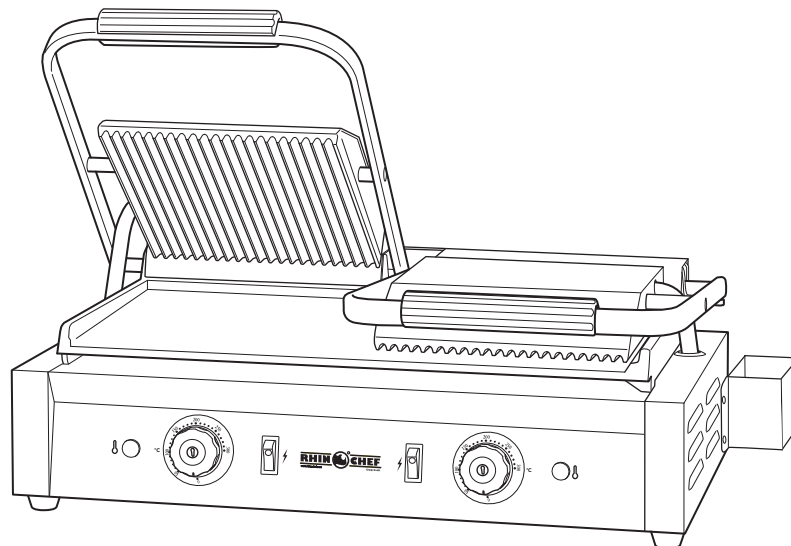

**Double Contact Grill RCG2**

### Contact Information

Rhinochef, County Oak Way, Crawley, West Sussex, RH11 7ST

**Customer Helpline: +44 (0) 1293 652 500** (9am - 5pm Monday to Friday) • Fax: +44 (0) 1293 652 555

Email: [info@rhinochef.com](mailto:info@rhinochef.com) • [www.rhinochef.com](http://www.rhinochef.com)



# SAFETY INFORMATION



**WARNING:** The installation, maintenance and servicing of this product must be carried out by a qualified technician.

You should consult local and national standards to comply with the following:

- Health & safety at work legislation
- BS EN Codes of practice
- Fire precautions
- IEE Wiring regulations
- Building regulations

**WARNING:** Incorrect installation, unauthorised modifications, refitting, adjustments, dismantling or maintenance could result in damage to the product, damage to property or serious injury. All repairs, maintenance and adjustments must be carried out by a qualified technician.

**WARNING:** RISK OF SEVERE BURNS. Take caution when using this product.

**WARNING:** ELECTRIC SHOCK RISK. **DO NOT** use when the power cord is damaged.

**WARNING:** For safety reasons, this product **MUST** be earthed.

The terminal marked  is for equipotential bonding.

**WARNING:** This is a commercial product and must only be used by a trained operative who has read and fully understands this manual. It must not be used by children or persons with reduced physical, sensory or mental capabilities.

Before using the product, ensure the rating marked on the product conforms to the electricity supply

Before using the product, check that electrical connection and earth connection, which is a separate pin on the back of the product, are secure.

Check power cord for damage prior to every use. If damage is found it can only be replaced by the manufacturer or a qualified technician.

**IMPORTANT:** The product should be given a visual safety check over every day to help prevent accidents.

**IMPORTANT:** The product should not be used if operator feels there is anything wrong with it. The problem should be referred to the manufacturer or a qualified technician.

Incorrect use of the product, other than its intended use, can cause damage to it and be dangerous.

The product surfaces and control panel may be damaged by hard or sharp objects.

**DO NOT** store any type of flammable liquid, gas or other similar items near or around this product.

**DO NOT** knock or bump the grill or place objects on top of it.

**DO NOT** lift the upper grill plate suddenly.

**CAUTION:** Be aware that surfaces of the product may be hot before and after it has been used - RISK OF SEVERE BURNS.

**DO NOT** use the product during a thunderstorm. To avoid it being damaged by a lightning strike, unplug it, removing it from electricity supply prior to the storm.

Allow the product to cool before cleaning.

Before cleaning, unplug the product from the mains power supply.

**DO NOT** use a water jet, a spray or splash water directly onto the product - RISK OF ELECTRIC SHOCK.

**DO NOT** submerge product, electric plug or power cord in water or other liquids.

**DO NOT** use wet cloths, steel wool pads or abrasive creams to clean the grill plates, surface of the grill or power cord. Use the wire brush provided with the grill and a clean, damp cloth.

When not in use, turn the temperature control to the '0' position and unplug the product from the mains power supply.

**EXTREME CAUTION:** Failure to follow instructions could result in damage to the product, damage to property or serious injury

To avoid risk of suffocation to children or animals, dispose of the plastic bags and packaging correctly.

For use with an earthed wall socket.

For indoor use only. Must **NOT** be used outdoors.

Not suitable for use with an extension cable.

Keep product and power cord out of reach of children and keep pets clear during use.

**DO NOT** position or use product underneath or near flammable items such as curtains, shelves, cupboards etc - FIRE HAZARD

**DO NOT** cover the product with anything - FIRE HAZARD

**DO NOT** try to dislodge food from the product when it is plugged in - RISK OF ELECTRIC SHOCK.

**DO NOT** allow the power cord to hang over the edge of a table or work surface on which the product stands.

**DO NOT** allow the power cord to come into contact with a heat source.

**DO NOT** use on or near direct heat sources.

**DO NOT** operate product with wet hands.

**DO NOT** operate product if damaged, or the cord, plug or appliance is damaged in any way.

**DO NOT** leave product unattended when in use.

**DO NOT** attempt to service the product yourself. Contact a qualified technician.

**DO NOT** use attachments other than those recommended by the manufacturer.

**CAUTION:** Do not pull or drag the product by the power cord.

The product must be placed and operated on a safe, flat and stable surface.

The product must be placed and operated on a safe, flat and stable surface.

Children should be supervised to ensure that they do not play with the appliance.

# THE CONTACT GRILLS

Thank you for purchasing this Rhinochef Contact Grill. The Rhinochef range includes three sizes: Single Contact Grill for individual portions, Panini Grill - perfect for paninis and a Double Contact Grill for versatility. Each model features robust cast iron plates with a sprung top plate for flexibility, a thermostatically-controlled temperature range of 50-300°C and a removable drip tray for easy cleaning.

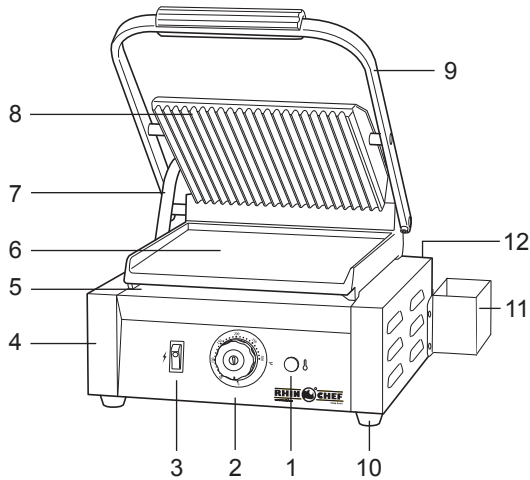

Single Contact Grill

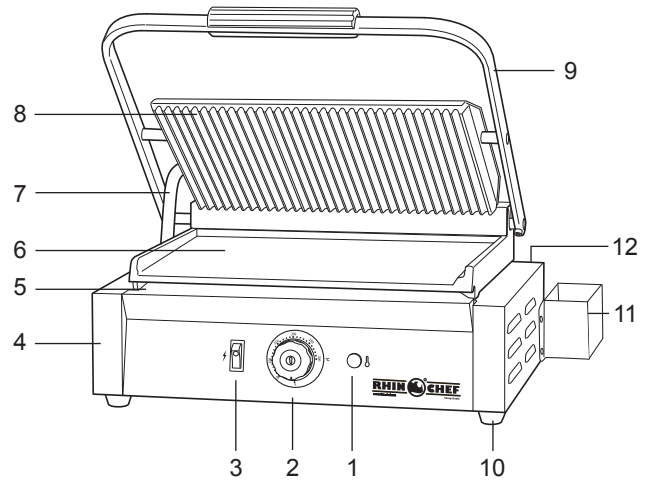

Panini Grill

## Contact Grill Parts:

1. Thermostat indicator (yellow light)
2. Temperature control
3. Power switch (green light)
4. Bottom box
5. Drip tray
6. Lower grill plate
7. Feed wire tube
8. Upper grill plate
9. Operation handle
10. Rubber feet
11. Wall spacer
12. Earth bolt 

**Note:** The Double Contact Grill has 2 plugs, one plug supplying power to each side.

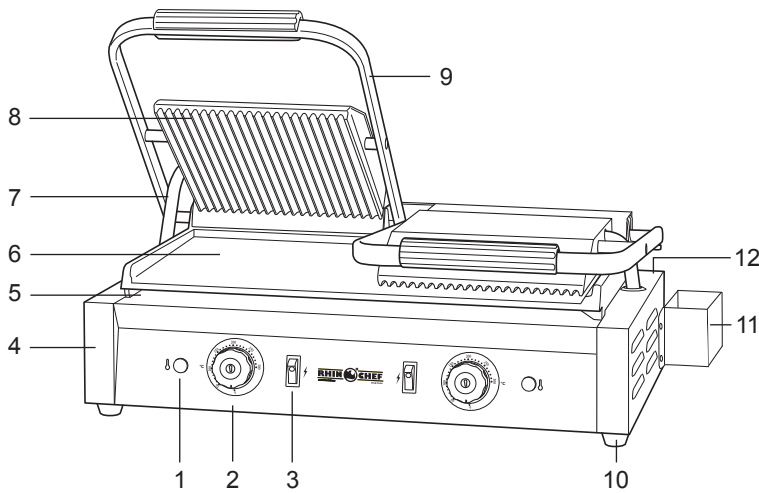

Double Contact Grill

# INSTALLATION

This grill is a plug-in product but commercial safety regulations require additional earthing to be carried out.

Only a suitably qualified technician should install the product.

There is an earth bolt at the back of the grill . Complying fully with safety regulations, connect the earth wire with suitable cable.

A suitable switch, fuse breaker and plug socket should be installed near the grill.

The wall spacers on the back/side will ensure there is a air gap around the machine.

You may see smoke coming from the machine when the machine is first switched on, this is normal.

# SETTING & USING THE CONTACT GRILL

## Adjusting the hinge speed

1. The hinging speed the top grill plate can be adjusted
2. Remove the single screw from the the back of the the hinge cover, then pull off the hinge cover. Using a 5mm allen key loosen or tighten the nuts to adjust the friction brake for the top grill plate

## Using the Contact Grill



**WARNING: RISK OF SEVERE BURNS. When used, parts of the grill will be hot to the touch.**

1. Before using the product, ensure that the electricity supply conforms to the rating markings on the grill and check there is no damage to the power cord.

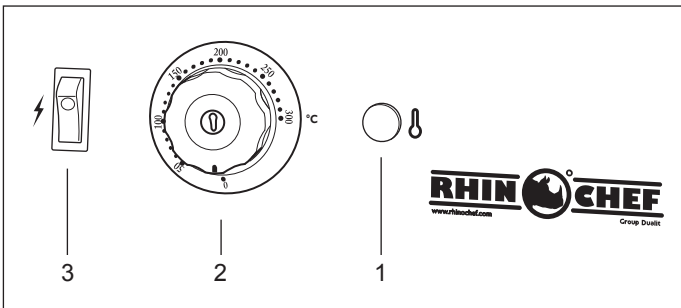

2. Ensure the grill is plugged into the socket and that power is switched on. Turn on the power switch (3) and the green power switch lights up.
3. Turn the temperature control (2) clockwise to required setting. The temperature can be adjusted according to what is being cooked within a range of 50 - 300°C.
4. A yellow indicator (1) lights up showing that the upper and lower grill plates are heating up. It will take about eight to ten minutes for the cooking temperature to reach 250°C from when the power is switched on.
5. When the temperature reaches required temperature, the yellow indicator light (1) goes out. The light will cycle on and off as the thermostat maintains the selected temperature.
6. Lift the upper grill plate with handle. Pour small amount of vegetable oil onto lower grill plate and place the food to be cooked onto it. Lower the upper grill plate and press handle lightly. Keep an eye on the food until it is cooked.
7. During cooking vegetable oil and animal fats will fall through to the drip tray beneath the lower grill plate.
8. To remove the food when it is cooked, lift the upper grill plate using the handle.
9. When cooking is finished, the temperature control must be turned to the '0' position and the power switch (3) turned off.
10. Unplug the grill from the mains power when not in use.

## Care, Maintenance, Storage and Transportation

**IMPORTANT:** Always unplug grill from the mains power socket and allow to cool completely before cleaning.

**DO NOT** spray or splash water directly onto the product.

**DO NOT** submerge grill, electric plug or mains lead in water or other liquids.

**DO NOT** use wet cloths, steel wool pads or abrasive creams to clean the grill plates, outer body of the grill or power cord.

Clean the grill plates with the wire brush included with the product and a clean, damp cloth for the rest of the grill.

Once cooled, remove the drip tray at the front of the grill by sliding it out. Wash in hot water and detergent. **DO NOT** slide tray back into grill until it is thoroughly dry.

When not in use, turn the temperature control to the '0' position and unplug the grill from the mains power supply.

Store grill in a safe, clean, dry, well ventilated place if it is not going to be used for any length of time.

Handle the grill with care when transporting.

**DO NOT** turn the grill upside down. This will help prevent the possibility of damaging it.

# TROUBLE SHOOTING

If a problem occurs that does not appear on this table, stop using the grill and seek help from the manufacturer, a qualified technician or an authorised dealer.

Problem	Cause(s)	Solution(s)
Grill plates not heated when power and thermostat indicator are both on.	<ol style="list-style-type: none"><li>1. Temperature control broken.</li><li>2. At least one heating element broken.</li><li>3. Overheat thermostat is activated.</li></ol>	<ol style="list-style-type: none"><li>1. Replace temperature control.</li><li>2. Replace broken heating element.</li><li>3. Reset the overheat thermostat.</li></ol>
Temperature cannot be controlled when power is on, temperature controller is on and thermostat indicator on.	Temperature control is broken.	Replace temperature control.
Indicator not on when power on and heating process normal.	Indicator is broken.	Neon indicator may need replacing.
Power indicator not on when power on.	<ol style="list-style-type: none"><li>1. Power cut or abnormal power supply.</li><li>2. Fuse in plug has blown.</li></ol>	<ol style="list-style-type: none"><li>1. Check plug and power supply.</li><li>2. Change fuse.</li></ol>

## SAFETY RESET

If for any reason the unit over heats, a safety cut-out is automatically activated.

This can be reset manually by unscrewing the black cap on the back of the grill and pushing the reset button.

Contact a qualified technician or an authorised dealer if safety reset repeatedly needs resetting during normal use.

# TECHNICAL SPECIFICATIONS

Model number	RCG1	RPG2	RCG2
<b>Description</b>	Single plate. With flat lower grill plate and ribbed upper grill plate.	Single plate. With flat lower grill plate and ribbed upper grill plate.	Double plate. With flat lower grill plate and ribbed upper grill plate.
<b>Voltage</b>	220-240V 50/60Hz	220-240V 50/60Hz	220-240V 50/60Hz
<b>Power</b>	1.8KW	2.2KW	3.6KW
<b>Temperature range</b>	50 - 300°C	50 - 300°C	50 - 300°C
<b>Upper grill plate size</b>	214 x 214mm	340 x 220mm	214 x 214mm
<b>Lower grill plate size</b>	218 x 230mm	360 x 285mm	475 x 230mm
<b>Dimensions</b>	370 x 435 x 210mm	490 x 410 x 220mm	650 x 435 x 210mm
<b>Weight</b>	14kg	20kg	28.5kg

# GUARANTEE

This appliance is of excellent quality and construction. However, if any defects in materials or workmanship do appear during the relevant guarantee period, we will, at our discretion, either repair or replace the defective parts, free of charge, subject to the terms and conditions of our Guarantee shown below.

This Guarantee covers both parts and labour. Carriage is not included.

Your Guarantee period is as follows:

- 1 year

This Guarantee provides benefits which are additional to, and do not affect, your statutory rights. This Guarantee does not cover the cost of returning the product to the dealer from whom it was purchased or to ourselves. This Guarantee applies only to products sold and located in mainland Great Britain. It does not cover liability in respect of or replacement of plugs, cables or fuses and also does not cover defects due to:

- Failure to use or maintain product in accordance with Dualit's instructions
- The product being connected to an unsuitable electricity supply
- Accidental damage to or abuse or misuse of the product
- The product has not been modified except by Dualit or approved agent
- Dismantling of or interference with the product
- Accidental breakage or damage
- Operational misuse, wear and tear from normal usage, incorrect adjustment and neglect
- Incorrect installation, maintenance, modification or unauthorised service work
- Theft or attempted theft of the product

Before returning any product under this Guarantee, please check that:

- You have followed the product instructions correctly
- Your mains electricity supply is functional
- The defect is not due to a blown fuse

If you wish to claim under this Guarantee you should:

- Send the product, postage or carriage paid, to the dealer from whom it was purchased or to Dualit direct
- Ensure that the product is clean and packed carefully (preferably in its original carton)
- Enclose details of your name, address and telephone number and when and where the product was purchased, together with proof of purchase (e.g. a till receipt)
- Give exact details of the nature of the defect

This Guarantee does not cover any other claims whatsoever, including, without limitation, any liability for incidental, indirect or consequential damage, nor does it cover any claims for conversion or modification or for the costs of repair carried out by any third party without the prior consent of Dualit. If replacement parts are fitted to the product this will not extend the period of the guarantee.

For further advice contact the Rhinochef Customer Helpline on: +44 (0)1293 652 500 (09:00 to 17:00 Monday to Friday).

Alternatively, email Dualit at [info@rhinochef.com](mailto:info@rhinochef.com) or visit [www.rhinochef.com](http://www.rhinochef.com).

## Disposal and the Environment



This product is covered by the waste electrical and electronic equipment (WEEE) regulations. It should not be discarded with normal household waste, but taken to a local collection centre for recycling. For further information, please contact the local authority or approved disposal agency.

Dispose of all packaging responsibly.

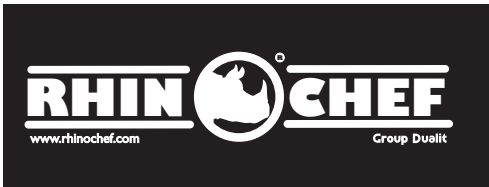

Rhinochef, County Oak Way, Crawley, West Sussex, RH11 7ST  
Telephone: +44 (0) 1293 652 500 Fax: +44 (0) 1293 652 555  
Email: [info@rhinochef.com](mailto:info@rhinochef.com) [www.rhinochef.com](http://www.rhinochef.com)

